

Balzano[®]
— 1908 Italy —

3D Turbo Air Fryer Instruction Manual



Model: RA-002DN

Important safeguards

- When using electrical appliances, basic safety precautions should always be followed, including the following:
- Read these instructions fully and make sure you understand the manual before using the appliance.
- This appliance is approved solely for use in accordance with the description and safety instructions specified in this user manual.
- Before cleaning and when not in use, unplug from the mains power supply.
- Do not leave the air fryer unattended when in use.
- To prevent anyone from tripping over the power cable, make sure that it is not draped over the worktop.
- Always place the appliance on a stable and flat surface and never place on or near a source of heat.
- This appliance is not to be used by persons (including children) with reduced physical, sensory or mental capabilities, or lack of experience and knowledge, unless they have been supervision or instruction concerning use of the appliance in a safe way and understand the hazards involved.
- Children being supervised not play with the appliance.
- Cleaning and user maintenance shall not be carried out by children unless they are supervised.
- This appliance is not to be operated with an external timer or separate remote-control system.
- The appliance should only be repaired by a qualified electrician. Never try to repair it yourself.
- Always use the original power cable supplied with the appliance.
- If the power cable is damaged, it must be replaced by an electrician. Make sure that the appliance and the power cable do not meet sources of heat such as a cooker top or naked flame. Make sure that the appliance has sufficient space around it.
- The appliance must not be covered.
- Make sure that the power cable and plug do not meet water.
- Never use the appliance outdoors.
- Make sure that your hands are dry when you touch the appliance, the power cable or the plug.
- Use tongs and if necessary, oven gloves to remove hot racks and containers.
- Always unplug the appliance by holding the plug, never pull on the power cord.
- Only use the attachments provided with the appliance.

- Do not move the appliance when it contains hot food or liquids.
- The outside of the appliance will be warm to touch during cooking process.
- Not suitable for commercial purposes.

Note: If the appliance malfunctions, switch off and unplug it from the mains power supply and contact a qualified electrician.

ELECTROMAGNETIC FIELDS (EMF)

This appliance complies with all requirements relating to electromagnetic fields (EMF).

SAVE THESE INSTRUCTIONS

General description

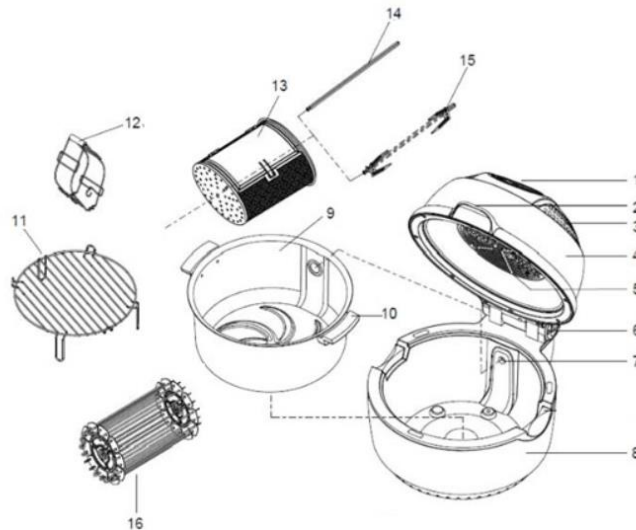

1. Control panel	9. Non-stick bowl
2. Lid handle	10. Bowl handle
3. Vent	11. Dual (high/low) rack
4. Transparent cover	12. Tongs
5. Heater and Fan	13. Rotisserie cage
6. Safety locking switch	14. Spindle for cage and chicken forks
7. Rotisserie spindle location	15. Chicken forks
8. Base	16. Rotisserie skewer cage

Control panel



Before first use

- Remove all packaging and make sure all parts are present.
- Internal accessories should be washed in hot soapy water, rinsed thoroughly and dried before use.

Note:

- Do not use abrasive chemicals as they will damage parts.
- Do not immerse any parts including the power cable in water, or let water run onto any parts.
- Do not clean any part of the fryer in a dishwasher.
- Always use the air fryer with the non-stick bowl inside.

If you need to remove food during the cooking process, lifting the handle will stop the heater and the fan while you attend to the dish. The fryer will not work unless the lid is closed and clicked into position. To start it you need to release the safety locking switch (6) at the rear of the lid. Then simply lower the lid to resume cooking.

Instructions for use

1. Insert the plug into the electrical outlet and switch on the plug. The air fryer will beep and show flashing lines.
2. When you are ready to start cooking, press the On/Off button.
3. You then need to select your required function, use the table below as a guide for temperature and cooking time.

Function	Temperature	Cooking time
Roast	200°C	25 minutes
Fry	230°C	25 minutes
Bake	180°C	15 minutes
Stir fry	200°C	10 minutes
Grill	190°C	15 minutes
BBQ	200°C	12 minutes

4. If you need to change the cooking temperature: after selecting the function, simply press the + or - buttons to increase or decrease the temperature.
5. If you need to change the cooking time: after selecting the function / temperature, simply press the TEMP/TIME button to show the pre-programmed time, then press the + or - buttons to increase or decrease the cooking time.

6. When you are ready to start cooking, press the START button and the air fryer will begin.
7. After selecting your cooking function, time and temperature, you can also then select whether you want to use the rotisserie function or not by pressing the rotisserie button. The red light will appear next to the rotisserie button if you are using the rotisserie function.

Pause function

If you open the lid during cooking the fryer will pause cooking but all data will be saved and continue when you close the lid. The rotisserie will continue to turn, and the on/off button can be used, all other buttons will be locked until the lid is closed.

Rotisserie function



The rotisserie aids the cooking of foods by evenly presenting the food to the heat source.



Opening and closing the lid.

To open, hold the handle at the front and lift upwards until you hear a click. This indicates that the safety lock has connected.

To close press down on the safety locking switch (6) at the back of the lid hinge as shown and lower the lid. When the lid is open it will move slightly, this is normal. During cooking, lifting the lid will stop the fryer cooking but allows you to taste the food with the fat from the meat or if preferred, a choice of sauce.



Accessory		Description of Usage
	Tongs	A handy tool for carrying food or plate in and out of the cooking bowl
	Dual (high/low) Rack	Low Rack: Good for cooking larger food items such as roast poultry (full size), rice casserole, vegetables, etc. High Rack: Suitable for cooking food with the medium size. Such as chicken wing and pizza.
	Rotisserie Cage	Suitable for French fries or other small size food. It can cook foods evenly.

	<p>Chicken Forks</p>	<p>Suitable for A whole chicken or big steak.</p>
	<p>Rotisserie Skewer Cage</p>	<p>Suitable for grilling shish kebab and skewers</p>

Using the accessories

Extreme caution must be used when moving the hot dish; we strongly advise you to use the tong to carry the food. Also when you take off or put back the inner pot (bowl). Please pay attention that whether the temperature of the inner pot is too high or not, use both hands to carry to prevent any accident.

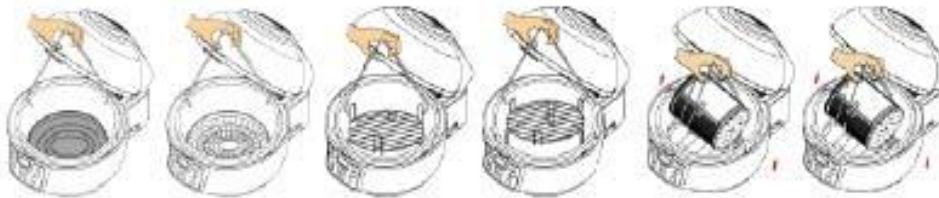

1. Dual rack : Low rack + High rack:



2. Forks for whole chicken:



3. Tongs and Rotisserie Cage



4. Tongs and Rotisserie skewer cage

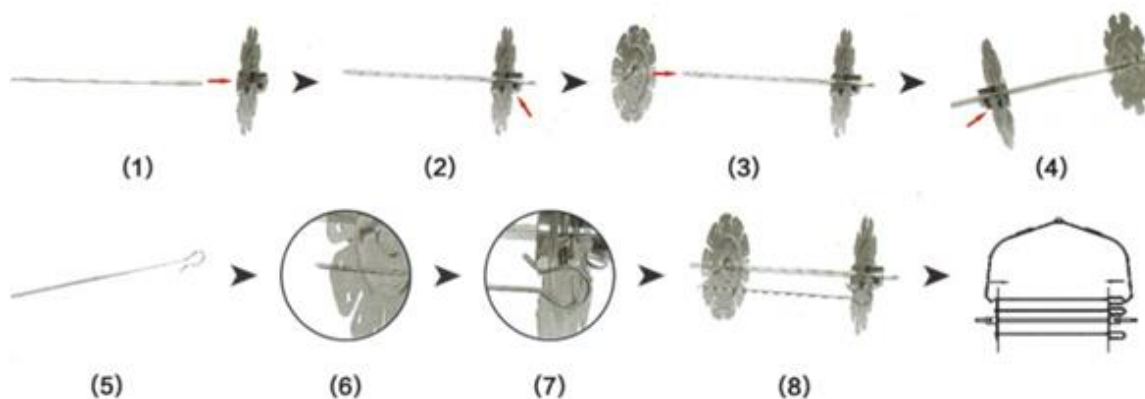

Cooking Tips

- Always place food centrally on all accessories to ensure good air circulation.
- Leave at least 1 cm gap between items on the rack to ensure good air circulation.
- When food is cooked it can be kept hot by turning the thermostat control to 150°C until ready to serve.
- When cooking chips use a small amount of vegetable oil.

Note: All time and temperatures are approximate and cooking time will depend on size of food to be cooked. During the latter part of cooking check the food and increase time accordingly until the food is cooked to your preference.

- The dual rack has 2 heights to select low or high turn the rack with either short legs down or long legs down.

Important note: Temperature and conditions will affect the cooking times listed. Make sure all food especially poultry and seafood are fully cooked before consumption. Follow guidelines on packaging supplied with foodstuffs.

Food	Temperature	Time	Recommend accessory	Cooking function
Small whole chicken	200°C	60 mins	Forks or low rack	Roast
Chips	230°C	20-25mins	Rotisserie cage with vegetable oil	Fry
Steaming fish	230°C	10-15mins	High Rack and aluminum foil	Fry
Cashew nuts	200°C	5-8mins	Rotisserie cage	Stir fry
Coffee beans	230°C	15-20mins	Rotisserie cage	Fry
Chicken wings	200°C	10-15mins	Rotisserie cage / High Rack aluminum foil	Stir fry
Steak	190°C	12-16mins	High Rack	Grill
Toast	230°C	5-8mins	High Rack	Fry
Prawns	200°C	5-8mins	High Rack	Stir fry
Bread	180°C	15-20mins	Low Rack	Bake

- Food should not exceed 5kg.

Care and maintenance

During use where possible use aluminum foil to line the base of the inner bowl to catch any fat or drips from the cooking process, this will protect the surface and aid cleaning.

After every use, make sure the fryer has cooled down and is unplugged. Remove all accessories and inner bowl, wash them in hot soapy water and then rinse and dry thoroughly. Parts are not suitable for the dishwasher.

For all external and inner surfaces, use hot water on a clean soft cloth with an antibacterial cleaning agent. Wipe all inner and outer surfaces, and then use a dry cloth to remove any water.

Store in a cool dry place until required again

DISPOSAL OF ELECTRICAL APPLIANCES



- This symbol means that this product shall not be disposed of with normal household waste.
- Follow your country's rules for the separate collection of electrical and electronic products. Correct disposal helps prevent negative consequences for the environment and human health.

Balzano products are intended for household use only

Balzano has policy of continuous improvement in product quality and design. The company, therefore reserves the right to change the specification of its model at any time.



www.balzano.com

